

CRS SERIES, RESONANT SCANNERS

RESONANT SCANNERS FOR HIGH SPEED IMAGING APPLICATIONS

Novanta develops photonics solutions through our globally recognized brands— ARGES, Cambridge Technology, Laser Quantum and Synrad— specializing in cutting-edge components and sub-systems for laser-based diagnostic, analytical, micromachining and fine material processing applications. Powerful lasers, coupled with advanced beam steering and intelligent sub-systems incorporating software and controls, deliver extreme precision and performance, tailored to our customers' demanding applications.

RAPID SCANNING RATES

Engineered by Cambridge Technology, our CRS Series of novel resonant scanners are ideally suited for high-speed imaging in real time. The CRS oscillates at a fixed, resonant frequency with a sinusoidal waveform; this unique scanner design enables a rapid scanning rate. The mirror is engineered out of lightweight beryllium, and broadband coatings reflect a wide range of laser wavelengths. When paired with a galvanometer, the CRS enables high-speed raster scanning over a two-dimensional field and is well-suited for microscopy and scanning laser ophthalmology applications.



ACHIEVE RELIABILITY FOR YOUR VALUE-DRIVEN APPLICATION

- Resonant scanners deliver fast scanning over large scan angles
- Reliable technology with extremely long lifetimes
- Straight-forward integration: stator-based design for simple mounting
- Driver board electronics included



Microscopy

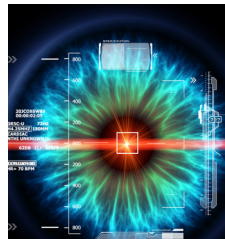

*Laser
Ophthalmology*

CRS SERIES, RESONANT SCANNERS

Specifications	CRS 4 KHz	CRS 8 KHz	CRS 12 KHz
Mirror Size	Ø 12.7 mm	7.8 x 5.5 mm ellipse	7.8 x 5.5 mm ellipse
Clear Aperture	12 x 9.25 mm	7.2 x 5.0 mm ellipse	7.2 x 5.0 mm ellipse
Resonant Frequency (at 25°C)	3,938 Hz	7,910 Hz	12,000 Hz
Frequency Tolerance (at 25°C)	± 50 Hz	± 15 Hz	± 50 Hz
Maximum Scan Angle (degrees, peak-to-peak)	24°	26°	10°
Trace to Retrace Wobble Repeatable (typical at maximum scan angle)	< 250 µrad	< 250 µrad	< 175 µrad
Typical Power Consumption	1.0 W	1.0 W	1.5 W
Wavelength Options	Broadband Coatings: Protected Aluminum or Protected Silver		
Frequency Thermal Stability	110 ppm/°C		
Velocity Feedback	Yes		
Driver Specifications			
Power Supply	Single rail, 12VDC		
Command Voltage	0-5V		
Scan Amplitude Control	Yes		
Sync Signal	Yes, occurs at each change in direction		
Dimensions (L x W)	30.5 mm x 43 mm	30.5 mm x 43 mm	30.5 mm x 43 mm

Notes:

All angles are in optical degrees, unless otherwise noted. All specifications are subject to change without notice.

CRS SERIES, RESONANT SCANNERS

CRS 4 KHz

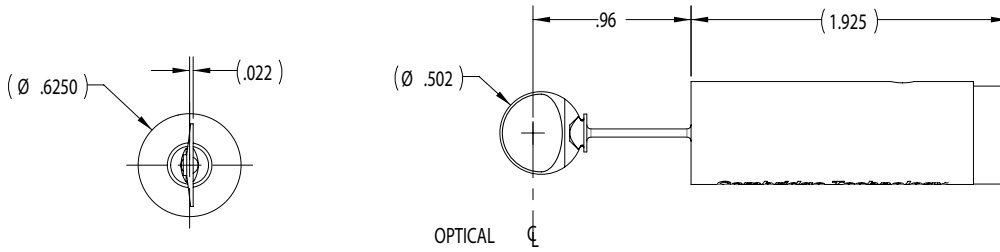

CRS 8 KHz and CRS 12 KHz

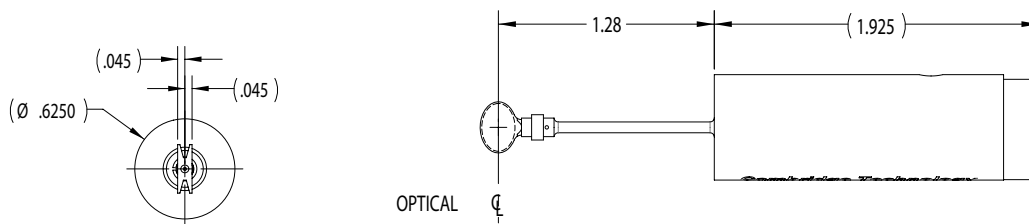

CRS DRIVER BOARD

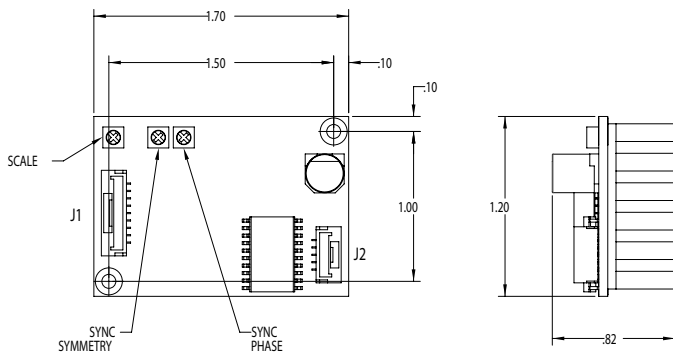

Pin	Signal	Comments
1	GND	
2	Velocity	Unscaled; for safety verification only
3	Sync	At each change in direction
4	Fault	Not in regulation
5	Disable	Pull down to disable servo
6	Power	12V DC
7	GND	
8	GND	
9	Ext. Amplitude Control	0-5VDC!; zero to full scan angle

Notes:

Dimensions are in millimeters. All specifications are subject to change without notice.

1. For the CRS 4kHz, Amplitude Control is limited to 0-4VDC to stay within max scan angle operation of 24°

CONTACT US

Americas, Asia Pacific

Novanta Headquarters
Bedford, USA
P +1-781-266-5700

Photonics@Novanta.com

Europe, Middle East, Africa

Novanta Europe GmbH
Wackersdorf, Germany
P +49 9431 7984-0

Milan, Italy
P +39-039-793-710

Photonics@Novanta.com

China

Novanta Sales & Service Office
Shenzhen, China
P +86-755-8280-5395

Suzhou, China
P +86-512-6283-7080

Photonics.China@Novanta.com

Japan

Novanta Service & Sales Office
Tokyo, Japan
P +81-3-5753-2460

Photonics.Japan@Novanta.com



www.NovantaPhotonics.com